

# *Instruction Manual*

## XDD 1 MKII/115/230 V and 24 V DC Diaphragm Pumps



Description	Item Number
XDD 1 115/230 V	A746-02-983
XDD 1 24 V	A746-02-991





# Declaration of Conformity

We, Edwards,  
Crawley Business Quarter,  
Manor Royal,  
Crawley,  
West Sussex, RH10 9LW, UK

declare under our sole responsibility, as manufacturer and person within the EU authorised to assemble the technical file, that the product(s)

- XDD1 AC Diaphragm Pump A746-02-983 \*
- XDD1 24 V DC Diaphragm Pump A746-02-991 #

to which this declaration relates is in conformity with the following standard(s) or other normative document(s)

EN1012-2:1996, A1: 2009	Compressors and Vacuum Pumps. Safety Requirements. Vacuum Pumps
EN61010-1: 2010	Safety Requirements for Electrical Equipment for Measurement, Control and Laboratory Use. General Requirements
EN61326-1: 2006	Electrical equipment for measurement, control and laboratory Use. EMC requirements. General requirements
*C22.2 1010.1-92+A2:97	Safety requirements for Electrical Equipment for Measurement, Control and laboratory use - Part 1: General requirements
#C22.2 61010-1-04+GI1 (R2009)	
UL61010A-1: 2002	Safety requirements for electrical equipment for measurement, Control and laboratory use - Part 1: General requirements
UL61010-1: 2004 R10.08	
EN50581: 2012	Technical Documentation for the Assessment of Electrical and Electronic Products with respect to the Restriction of Hazardous Substances

and fulfils all the relevant provisions of

2006/42/EC	Machinery Directive
2006/95/EC	Low Voltage Directive
2004/108/EC	Electromagnetic Compatibility (EMC) Directive
2011/65/EU**	Restriction of Certain Hazardous Substances (RoHS) Directive

*\*\* i. e. The product(s) contain less than - 0.1wt% for hexavalent chromium, lead, mercury, PBB and PBDE; 0.01wt% for cadmium - in homogeneous materials (subject to the exemptions allowed by the Directive). The RoHS Directive does not legally apply to industrial vacuum equipment until July 2019 (July 2017 for instruments).*

*Note: This declaration covers all product serial numbers from the date this Declaration was signed onwards.*

Peter Meares  
GV Technical Support Manager

15.07.2013, Burgess Hill

Date and Place

*This product has been manufactured under a quality system registered to ISO9001*

# Contents

Section	Page
1	Introduction ..... 1
1.1	Safety information ..... 1
2	Technical data ..... 7
3	Installation ..... 11
3.1	Electrical connection ..... 11
3.1.1	XDD1 dual-voltage motor ..... 11
3.1.2	XDD1 24 V dc ..... 12
3.2	Configure the XDD1 24V dc internal speed setting ..... 13
3.3	Configuring the XDD1 24V dc for external analogue (0 - 10 V) speed control ..... 13
3.4	Notes regarding the motor speed ..... 14
4	Use and operation ..... 15
4.1	Installing in a vacuum system ..... 15
4.2	Prior to use ..... 15
4.3	During operation ..... 15
4.3.1	Pumps with dual-voltage motor ..... 15
4.3.2	Pumps with 24 V dc voltage ..... 15
4.4	Shutdown ..... 16
4.4.1	Short term ..... 16
4.4.2	Long term ..... 16
5	Maintenance ..... 17
5.1	Replacing diaphragms and valves ..... 17
5.1.1	Cleaning and inspecting the pump heads ..... 20
5.1.2	Replacing the diaphragm ..... 22
5.1.3	Assembling pump heads ..... 24
5.1.4	Assembling fittings ..... 28
5.1.5	If the pump does not achieve the ultimate pressure ..... 28
6	Storage and disposal ..... 31
6.1	Storage ..... 31
6.2	Disposal ..... 31
7	Spares and accessories ..... 33
7.1	List of spare parts ..... 33

For return of equipment, complete the HS Forms at the end of this manual.

## Illustrations

Figure		Page
1	General view of XDD 1 with dual-voltage motor .....	4
2	General view of XDD 1 24 V DC .....	5
3	Dimensional drawing XDD 1 (dual-voltage motor) .....	9
4	Dimensional drawing XDD 1 24 V DC .....	10
5	Adjust the supply voltage .....	11
6	Replacing the motor fuse (dual-voltage motor) .....	12
7	Internal speed setting .....	13
8	View of the disassembled pump head parts .....	19
9	Tools required .....	20
10	Remove the fitting at the pump head .....	20
11	Remove the handle .....	21
12	Remove the housing cover and head cover .....	21
13	Remove the head cover from the housing cover .....	22
14	Lift the diaphragm .....	23
15	Position a new diaphragm .....	23
16	Diaphragm clamping disc .....	24
17	Assemble the diaphragm assembly to the connecting rod .....	24
18	Position the diaphragm .....	25
19	Assemble the head cover and valves .....	25
20	Scheme pump head with head covers .....	26
21	Scheme pump head with head covers and valves .....	26
22	Position the housing cover .....	27
23	Assemble the handle .....	27
24	Assemble the fitting at the pump head .....	28

## Tables

Table		Page
1	Electrical data .....	7
2	Performance data .....	7
3	Environmental operating and storage data .....	7
4	Mechanical data .....	8
5	Materials data .....	8
6	Logic interface connector pins .....	12
7	Troubleshooting .....	29
8	Spare parts .....	33

## Trademark credits

Viton® is trademark of DuPont Dow Elastomers L.L.C.

# 1 Introduction

## 1.1 Safety information

Remove all packing material, remove the product from its packing-box, remove the protective covers from the inlet and outlet ports and keep them, inspect the equipment. If the equipment is damaged, notify the supplier and the carrier in writing within three days; state the item number of the product together with the order number and the supplier's invoice number. Retain all packing material for inspection.



### **WARNING**

Do not use the equipment if it is damaged.

If the equipment is not used immediately, replace the protective covers. Store the equipment in suitable conditions.

- Read and obey this manual before installing or operating the equipment.
- Transport the pump at the provided handle or the recessed grip.

The following symbols appear in this document:



Warning - refer to accompanying documentation.



Warning - Isolate equipment from mains. - risk of electric shock.



Warning - Hot surfaces.



Warning - Use protective equipment.

Use the equipment for the intended use only, i. e. for generation of vacuum.

- Prevent any part of the human body from coming in contact with the vacuum.
- Obey notes on correct vacuum and electrical connections.
- Make sure that the individual components are only connected, combined and operated according to their design and as indicated in the instructions for use.

- If the equipment is brought from cold environment into a room for operation, allow the equipment to warm up (pay attention to water condensation on cold surfaces).
- Make sure ventilation is adequate if pump is installed in a housing or if ambient temperature is elevated.

Obey all relevant safety requirements (regulations and guidelines) and adopt suitable safety measures.

- Provide a firm level platform for the equipment and check that the system to be evacuated is mechanically stable and that all fittings are secure.

*Note:* Flexible elements tend to shrink when evacuated.

Due to the high compression ratio of the pumps, pressure at the outlet port might be generated being higher than the max. permitted pressure compatible with the mechanical stability of the system.



### WARNING

Obey maximum permitted pressures and pressure differences, see [Section 2](#) Technical data. Do not operate the pump with overpressure at the inlet.



### WARNING

Do not permit any uncontrolled pressurizing (e. g. make sure that the exhaust pipeline cannot become blocked). If you have an exhaust-isolation valve, make sure that you cannot operate the equipment with the valve closed. Risk of bursting!

Ensure that the system design does not allow the exhaust pipeline to become blocked:

- Avoid overpressure of more than 0.2 bar in case inert gas is connected.
- The diameter of the inlet and outlet pipeline should be at the least as large as the diameter of the pump connection pipelines.
- Adopt suitable measures in case of differences, e. g. using the equipment outdoors, installation in altitudes of more than 1000 m above mean sea level, conductive pollution or moisture.



### WARNING

Pay attention to symbol "hot surfaces" on the equipment. Adopt suitable measures to prevent any danger arising from the formation of hot surfaces or electric sparks.



### WARNING

The pumps are not suitable to pump dangerous or explosive gases or explosive or flammable mixtures. Ensure that the materials of the wetted parts are compatible with the pumped substances, see [Section 2](#) Technical data.

Adopt suitable measures to prevent the release of dangerous, explosive, corrosive or polluting fluids.

Use inert gas for gas ballast or venting if necessary.

The user must take suitable precautions to prevent any formation of explosive mixtures in the expansion chamber. In case of a diaphragm crack, mechanically generated sparks, hot surfaces or static electricity may ignite these mixtures.

Take adequate precautions to protect people from the effects of dangerous substances (chemicals, thermal decomposition products of fluoroelastomers), wear appropriate safety clothing and safety glasses.

Obey applicable regulations when disposing of chemicals. Take into consideration that chemicals may be polluted.

**WARNING**

Pumps with dual-voltage motor: The motor is shut down by a thermal cutout in the winding.

Manual reset is necessary. Switch off the pump or isolate the equipment from mains. Wait approx. five minutes before restarting the pump.

**WARNING**

Pumps with 24 V DC voltage: The motor is protected by a temperature sensor at the circuit board (current limitation if the temperature at the circuit board is higher than 70°C).

Avoid high heat supply (e. g. due to hot process gases).

Ensure sufficient air admittance if pump is installed in a housing.

Due to the residual leak rate of the equipment, there may be an exchange of gas, albeit extremely slight, between the environment and the vacuum system.

- Adopt suitable measures to prevent contamination of the pumped substances or the environment.

Ensure that in case of failure, the pump and the vacuum system turn always into a safe status.

- In case of leaks in the manifold pumped substances may leak into the environment or in the pump housing or the motor.
- Obey especially all notes on use and operation and on maintenance.
- Failure of the pump (e. g. due to power failure) must not lead to a critical dangerous situation under any circumstances.

Use only genuine spare parts and accessories.

- Otherwise safety and performance of the equipment as well as the electromagnetic compatibility of the equipment might be reduced.

Figure 1 - General view of XDD 1 with dual-voltage motor

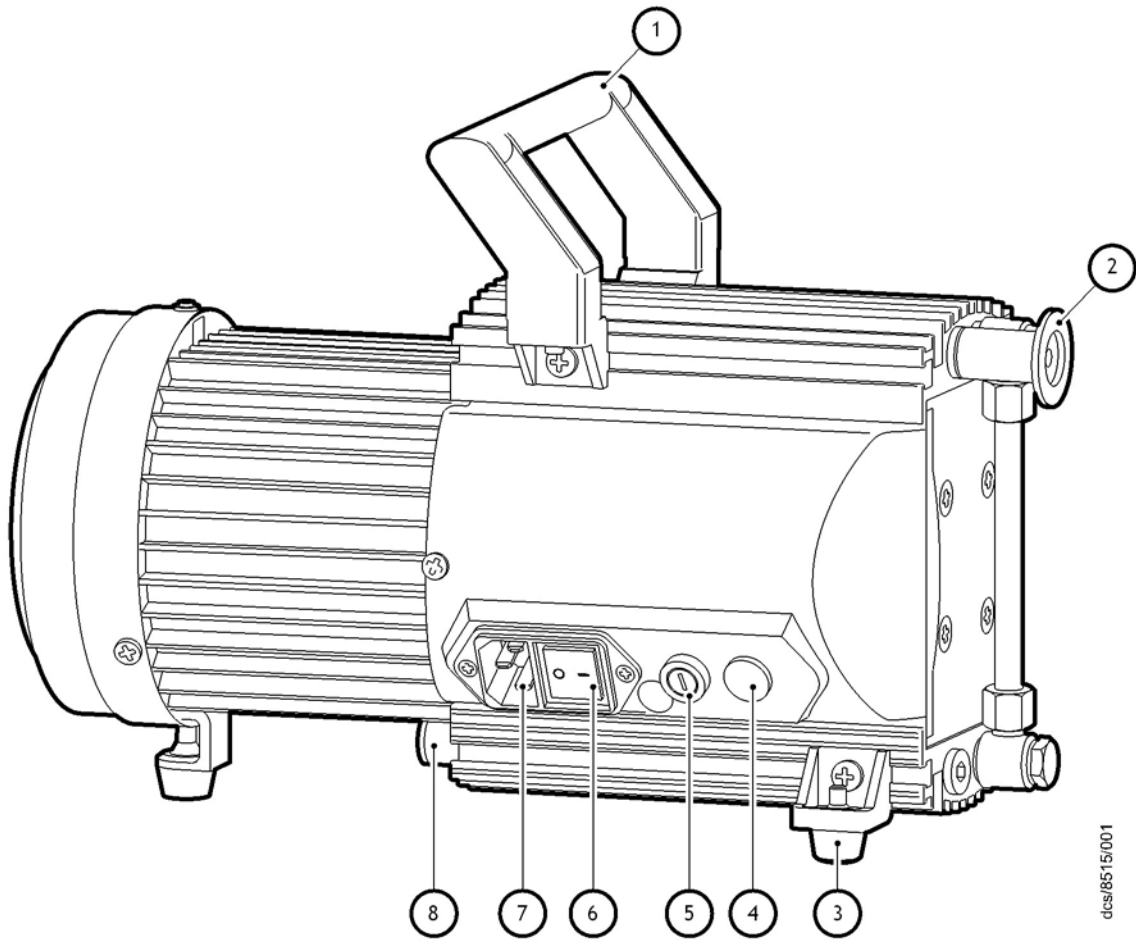

dcs/8515/001

- |                              |                      |
|------------------------------|----------------------|
| 1. Handle (removable)        | 5. Fuse holder       |
| 2. Inlet (small flange) NW16 | 6. Mains switch      |
| 3. Pump feet (adjustable)    | 7. Mains input       |
| 4. Voltage selector switch   | 8. Outlet (silencer) |



Figure 2 - General view of XDD 1 24 V DC

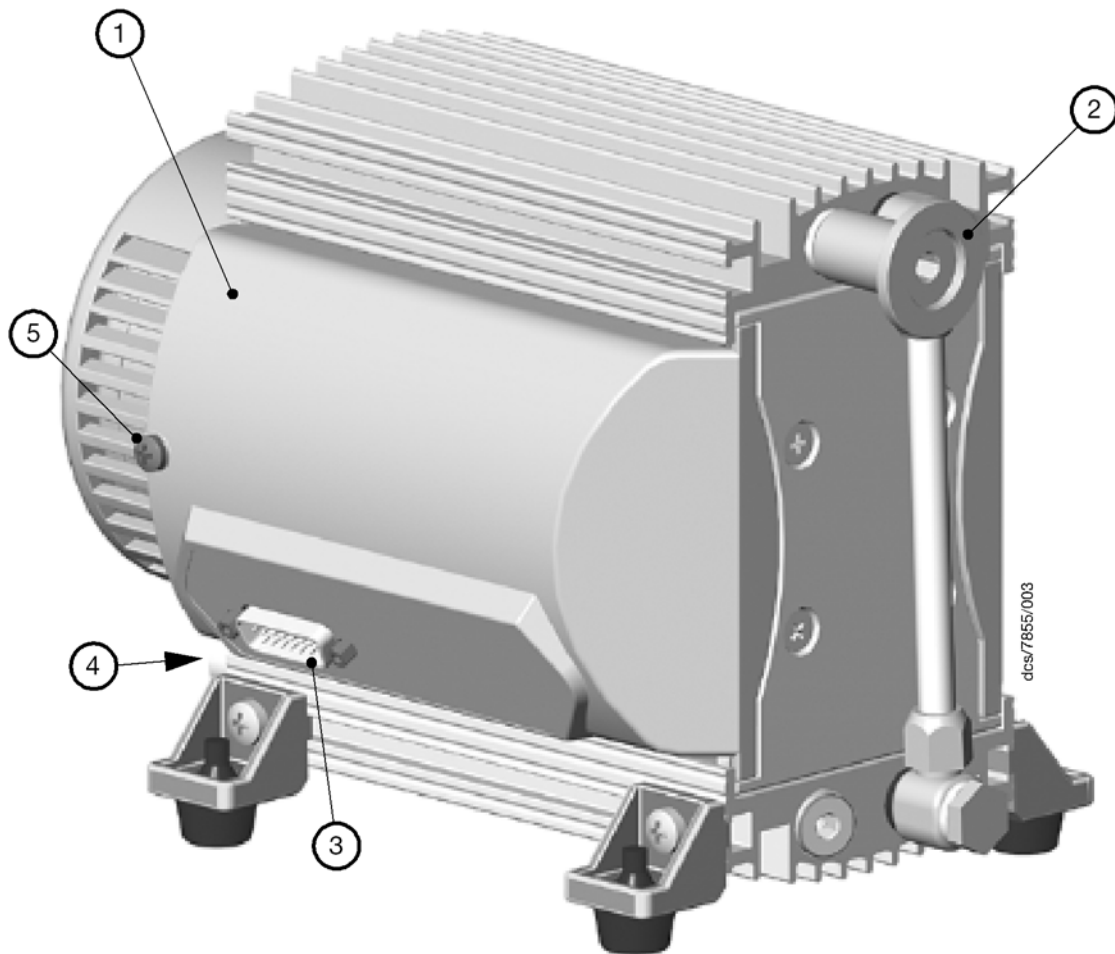

1. Cover of the circuit board
2. Inlet (small flange) NW 16
3. Male 15 pin D-connector
4. Outlet (silencer) at lower side
5. Screw to secure cover

This page has been intentionally left blank.

## 2 Technical data

**Table 1 - Electrical data**

Parameter		XDD1 115/230 V 50/60 Hz	XDD1 24 V DC
Motor power	kW	0.08	0.064
Maximum permitted range of supply voltage (±10%)		Attention* 100-120 V 50/60 Hz 200-230 V 50/60 Hz	24 V DC
Maximum rated current:			
100-120 V 50/60 Hz	A	1.6 / 1.7	-
200-230 V 50/60 Hz	A	0.8 / 0.85	-
24 V DC	A	-	7
Motor protection		Thermal cut-out, manual reset	Temperature sensor on the PCB (current limitation)
Fuse		20 mm x 5 mm, 250 V, 2.5 A type T	

\* Voltage selection switch

**Table 2 - Performance data**

Parameter		XDD1 115/230 V 50/60 Hz	XDD1 24 V DC
Pumping speed (ISO 21360)	m <sup>3</sup> /h	1.2 / 1.4	1.7 (2200 rpm) 1.4 (1700 rpm)*
Ultimate vacuum (absolute)	mbar	1.5	< 1.0 (700 rpm)
No-load speed	min <sup>-1</sup>	1500 / 1800	100 - 2200
Maximum permissible outlet pressure (absolute)	bar		1.1
Maximum pressure difference between inlet and outlet	bar		1.1

\* Factory set

**Table 3 - Environmental operating and storage data**

Parameter		XDD1 115/230 V	XDD1 24 V DC
		IP 40	IP 20
Degree of protection IEC 529		IP 40	IP 20
Permitted ambient temperature storage / operation	°C	-10 to +60 / +10 to +40	
Permitted relative atmospheric moisture during operation (no condensation)	%	30 to 85	
Maximum operating altitude	m	2000	
IEC rated pollution degree		2	
Sound level	dBA	45	
Area of use		Indoor use only	

Table 4 - Mechanical data

Parameter	XDD1 115/230 V	XDD1 24 V DC
Mass kg	6.7	4.1
Overall dimensions	Refer to Figure 3	Refer to Figure 4
Inlet connection	Small flange NW 16	
Outlet connection	Silencer G 1/8 inch	

Table 5 - Materials data

Components	Wetted parts
Housing cover	Aluminium
Head cover	Aluminium
Diaphragm clamping disc	Aluminium
Valve	FPM (e.g. Viton®)
Diaphragm	PTFE -FPM (e.g. Viton®) sandwich
Inlet (small flange)	Stainless steel
Outlet (silencer)	Aluminium / silicon caoutchouc
Hose	PE
Fitting	Aluminium anodized

Figure 3 - Dimensional drawing XDD 1 (dual-voltage motor)

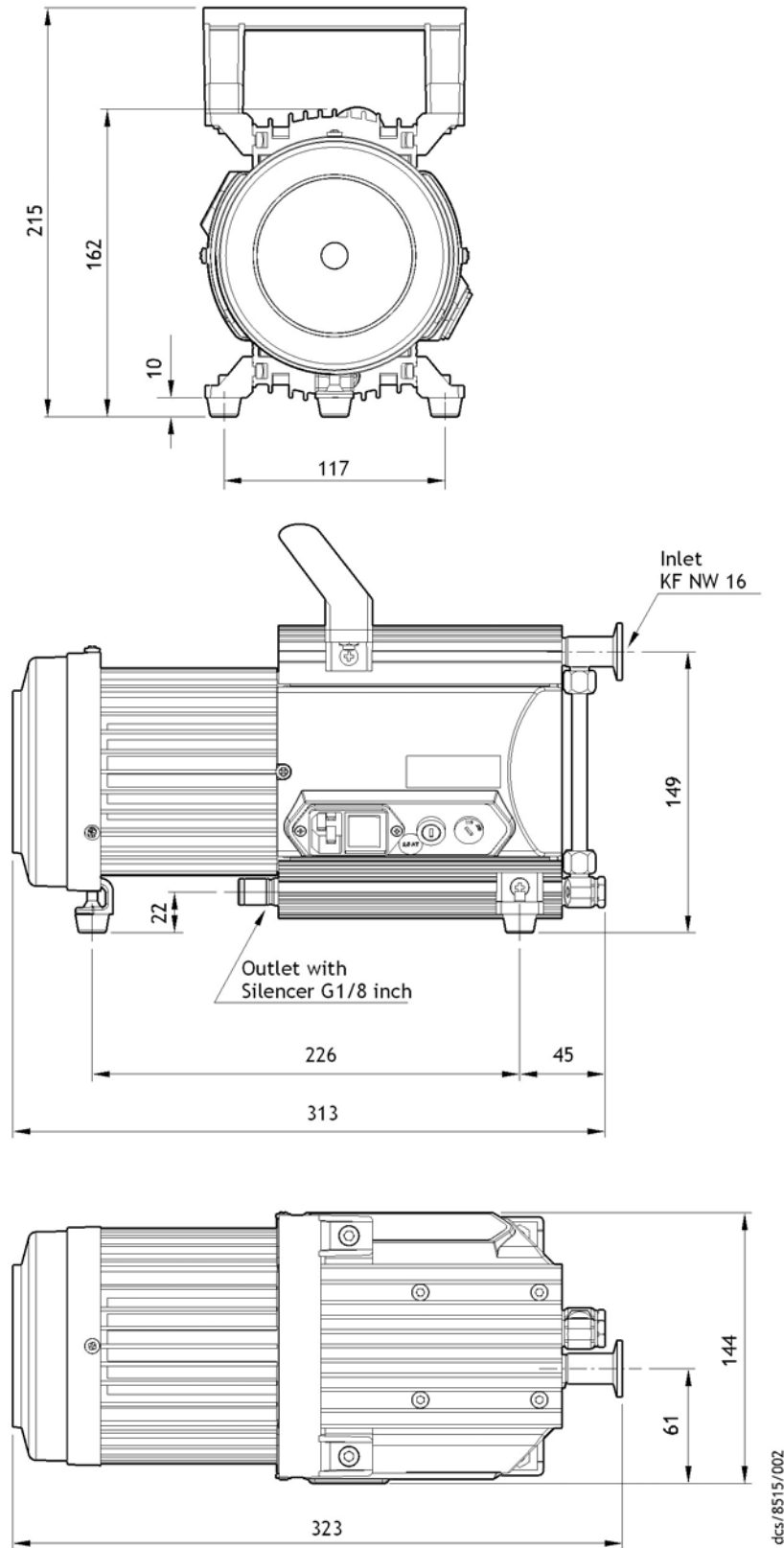
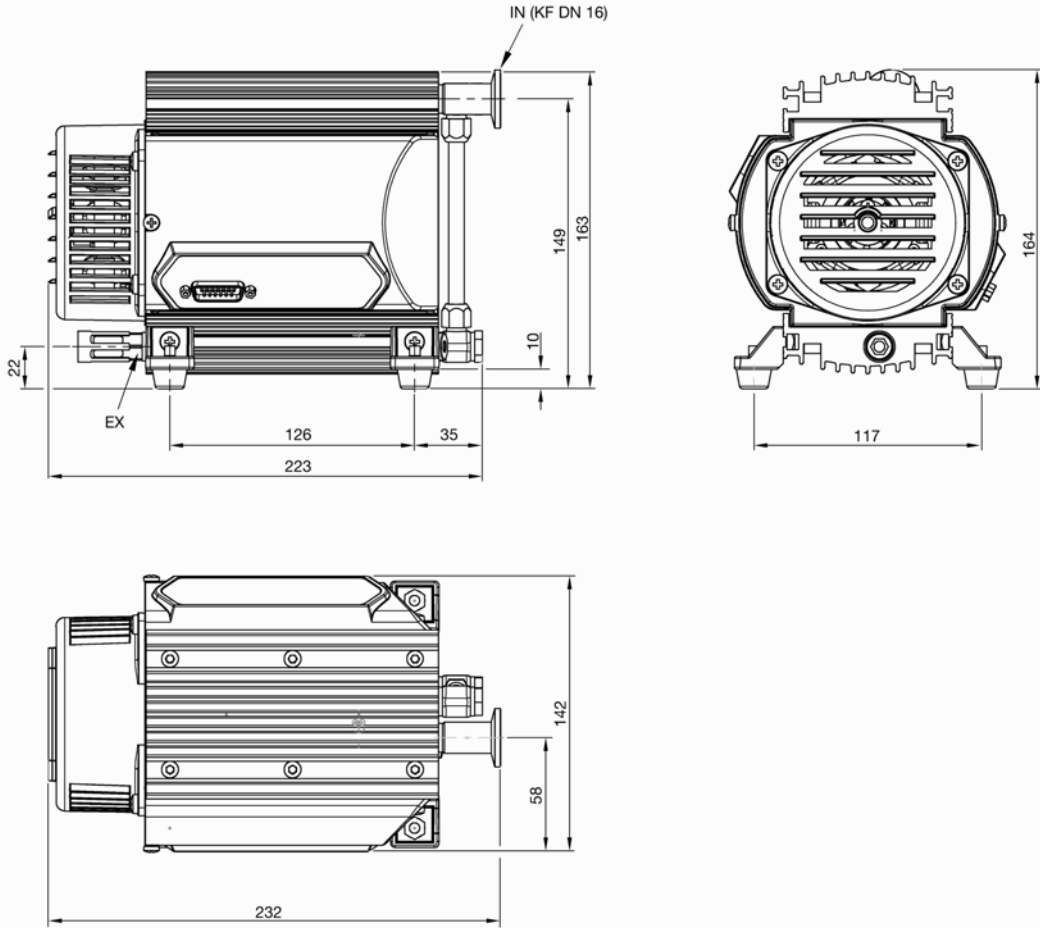

Figure 4 - Dimensional drawing XDD 1 24 V DC



dcx7855/013

## 3 Installation

*Note:* A suitably trained or qualified technician must carry out the following procedures.

### 3.1 Electrical connection

#### 3.1.1 XDD1 dual-voltage motor

---

**CAUTION**

Ensure that the motor is correctly configured for your electrical supply. If you operate the pump when the motor is not correctly configured for the electrical supply, you will damage the motor.

---

**CAUTION**

Do not change the voltage selector switch while the pump is connected to the mains supply.

---

Figure 5 - Adjust the supply voltage



1. Voltage selector switch

1. Selecting 115 covers a voltage supply range of 100 V to 120 V.
2. Selecting 230 covers a voltage supply range of 200 V to 240 V.

Ensure that the voltage shown on the voltage selector switch (Figure 5, item 1) corresponds with your electrical supply voltage. If it does not, you must change the configuration of the pump motor using the voltage selector switch to match your supply voltage. Use a screw driver to adjust the selector switch to the correct voltage.



**WARNING**

Ensure that the electrical installation of the XDD1 mains pump conforms with your local and national safety requirements. It must be connected to a suitably fused and protected electrical supply and suitable earth point. For electrical data refer to [Table 1](#).

---

Figure 6 - Replacing the motor fuse (dual-voltage motor)



dcs/8515/004

1. Carefully remove the fuse holder at the side of the pump (refer to [Figure 1](#), item 5).
2. Replace the defective fuse with a 2.5 A type T and secure the fuse carrier back into its holder.

### 3.1.2 XDD1 24 V dc

The pump has been factory set to a constant pumping speed when connected to a 24 V DC (=/-10%) supply. The pump can also be controlled using an external analogue 0-10 V signal. Use a suitable connector mating half (not supplied) to connect the electrical supplies and your control equipment to the connector on the logic interface cable. When you make the electrical connections to the XDD 1, refer to [Table 6](#) for full details of the logic interface connections.

Table 6 - Logic interface connector pins

Pin number	Signal	Use
2	Control / monitor: 0 V signal	-
4	XDD 1 identity	
9	Speed (0-10 V)	To control motor speed
8, 13, 14	Electrical supply: 0 V	Use all pins for connection!
1, 6, 11	Electrical supply 24 V	Use all pins for connection!



Figure 7 - Internal speed setting

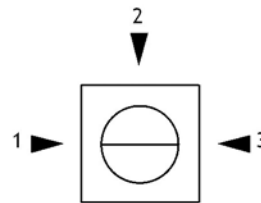

Position 1 - zero speed, set for external motor speed signal  
 Position 2 - normal motor speed 1700 rpm (factory set)  
 Position 3 - maximum motor speed 2200 rpm

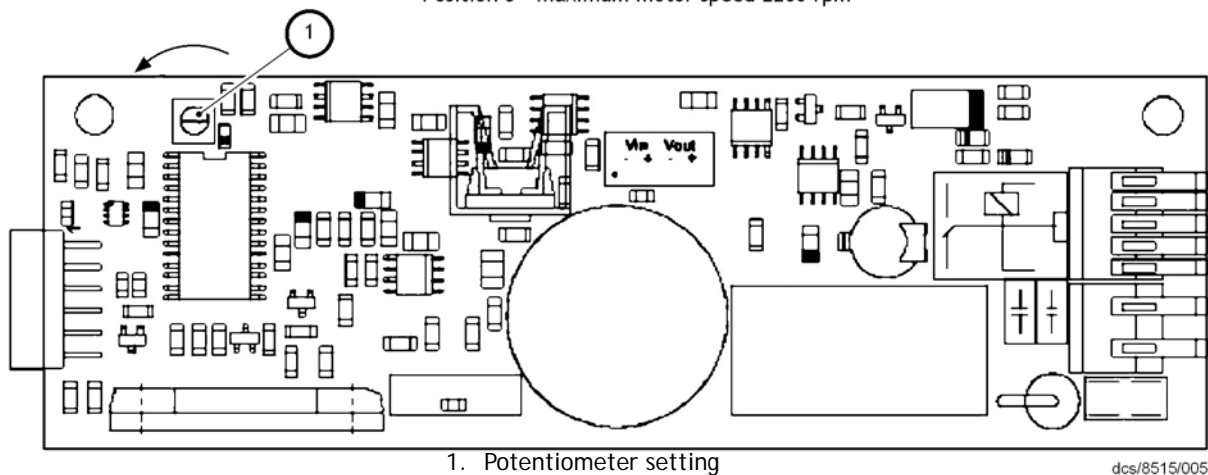

1. Potentiometer setting

dcs/8515/005

### 3.2 Configure the XDD1 24V dc internal speed setting

There are two internal speed settings, use the following procedure to adjust the internal speed control (refer to Figure 7).

Remove the screw which secures the cover to the circuit board (refer to Figure 2, item1) Move the cover carefully and only as far as necessary. Using a screw driver, turn the potentiometer to one of two positions. Set to position 2 for normal speed or position 3 if maximum throughput is required (refer to Figure 7). Assemble the cover in reverse order.

### 3.3 Configuring the XDD1 24V dc for external analogue (0 - 10 V) speed control

Remove the screw which secures the cover to the circuit board (refer to Figure 2, item1) Move the cover carefully and only as far as necessary. Using a screw driver turn the potentiometer anti-clockwise to position 1 (refer to Figure 7). Assemble the cover in reverse order. Apply external analogue 0-10 V signal for motor speed control.

Voltage input: analogue 0 V...10 V

<0.5 V : Pump stopped

0.5 V to 10 V : Linear increase of the motor speed (~100 rpm to 2200 rpm)

*Note:* Pump runs smoothly only at speeds > 200 rpm (> ~0.9 V).

### 3.4 Notes regarding the motor speed

Operating the pump at high motor speeds increases the pump throughput, this will also cause the pump to generate more heat. Ensure there is adequate ventilation especially when using the pump within confined spaces or enclosures.

Operating the pump at low motor speeds increases the ultimate vacuum performance, this will also increase the lifetime of the diaphragm and valves.

## 4 Use and operation

### 4.1 Installing in a vacuum system

The pump can be mounted in any orientation.

Avoid throttling losses by using connecting pipes with large diameter and keep them as short as possible.

Reduce the transmission of vibration and prevent loading due to rigid pipelines. Insert elastic hoses or flexible elements as couplings between the pump and rigid pipes.

*Note:* Flexible elements tend to shrink when evacuated.

Use a suitable valve to isolate the pump from the vacuum system to allow the pump to warm up before condensable vapours are pumped or to clean the pump before it is switched off.

Connect the exhaust to a suitable treatment plant to prevent the discharge of dangerous gases and vapours to the surrounding atmosphere. Use a catchpot to prevent the drainage of contaminated condensate back into the pump.

### 4.2 Prior to use

*Note:* Max. ambient temperature: 40 °C.

Make sure ventilation is adequate if pump is installed in a housing or if ambient temperature is elevated. Keep a distance of min. 20 cm between fans and ambient parts.

When assembling, ensure vacuum-tightness. After assembly, check the complete system for leaks.

### 4.3 During operation

---

#### CAUTION

Do not start or operate the pump if pressure at the outlet is higher than 1.1 bar absolute. Attempts to start or operate the pump at higher pressure may cause blockade and damage of the motor.

---

The pump achieves its **pumping speed**, **ultimate total vacuum** and **vapour pumping rate** only at operating temperature (after approx. 15 minutes).

Prevent internal condensation, transfer of liquids or dust. The diaphragm and valves will be damaged, if liquids are pumped in significant amounts.

#### 4.3.1 Pumps with dual-voltage motor

Motor is shut down by a **thermal cutout** in the winding. Manual reset is necessary. Switch off the pump or isolate the equipment from mains. Wait approx. five minutes before restarting the pump. Identify cause of failure and eliminate.

*Note:* Pump starts again after power failure.

#### 4.3.2 Pumps with 24 V dc voltage

The motor is protected by a **temperature sensor at the circuit board** (current limitation if the temperature at the circuit board is higher than 70°C).

## 4.4 Shutdown

### 4.4.1 Short term

#### Fault

Has the pump been exposed to condensate?

#### Action

Allow the pump to continue to run at atmospheric pressure with inlet open for a few minutes.

Has the pump been exposed to media which may damage the pump materials or forms deposits?

Check and clean pump heads if necessary.

### 4.4.2 Long term

- Take measures as described in section short-term shutdown.
- Separate pump from the apparatus.
- Close inlet and outlet port (e. g. with transport caps).
- Store the pump in dry conditions.

## 5 Maintenance

Ensure that maintenance is done only by suitably trained and supervised technicians. Ensure that the maintenance technician is familiar with the safety procedures which relate to the product processed by the vacuum system and that the equipment, if necessary, is appropriately decontaminated before starting maintenance. Obey local and national safety regulations.



### WARNING

Before starting maintenance vent the system, isolate the pump and other components from the vacuum system and the electrical supply, drain condensate and allow sufficient cooling of the pump.  
Before starting maintenance, wait two minutes after isolating the equipment from mains to allow the capacitors to discharge.

In order to comply with law (occupational, health and safety regulations, safety at work law and regulations for environmental protection) vacuum pumps, components and measuring instruments returned to the manufacturer can be repaired only when certain procedures (see section Return of Edwards Equipment - Procedure (Forms HS 1 and HS 2) are followed.

### 5.1 Replacing diaphragms and valves



### WARNING

Please read section Replacing diaphragms and valves completely before starting maintenance.

*Note:* The images of the pumps may differ slightly, this does not influence replacing the diaphragm and valves.

All bearings are encapsulated and are filled with long-life lubricant, under normal operating conditions these parts are maintenance free.

The valves and the diaphragms are wear parts. If the rated ultimate vacuum is no longer achieved, the pump interior, the diaphragms and the valves must be cleaned and the diaphragms and valves must be checked for cracks or other damage.

Depending on individual cases it may be efficient to check and clean the pump heads on a regular basis. In case of normal wear the lifetime of the diaphragms and valves is > 10000 operating hours.

### CAUTION

Prevent internal condensation, transfer of liquids or dust. The diaphragm and valves will be damaged, if liquids are pumped in significant amount.

If the pump is exposed to corrosive gases or vapour or in case of deposits, maintenance should be carried out frequently.

*Note:* Regular maintenance will improve the lifetime of the pump and also protect both man and environment.



### WARNING

Before starting maintenance vent the system, isolate the pump and other components from the vacuum system and the electrical supply.

Drain condensate if applicable, avoid the release of pollutants. Allow sufficient cooling of the pump.

---

**CAUTION**

Ensure that the pump cannot be operated accidentally. Never operate the pump if covers or other parts of the pump are disassembled. Never operate a defective or damaged pump.

---

Ensure that the maintenance technician is familiar with the safety procedures which relate to the products processed by the pumping system. The pump might be contaminated with the process chemicals that have been pumped during operation. Ensure that the pump is decontaminated before maintenance and take adequate precautions to protect people from the effects of dangerous substances if contamination has occurred.

---

**WARNING**

Wear appropriate safety-clothing when you come in contact with contaminated components.

**WARNING**

For cleaning or removing deposits of the valves and diaphragms, use a suitable solvent. The use of any solvents must be used in accordance with your local health and safety regulations.

---

Figure 8 - View of the disassembled pump head parts

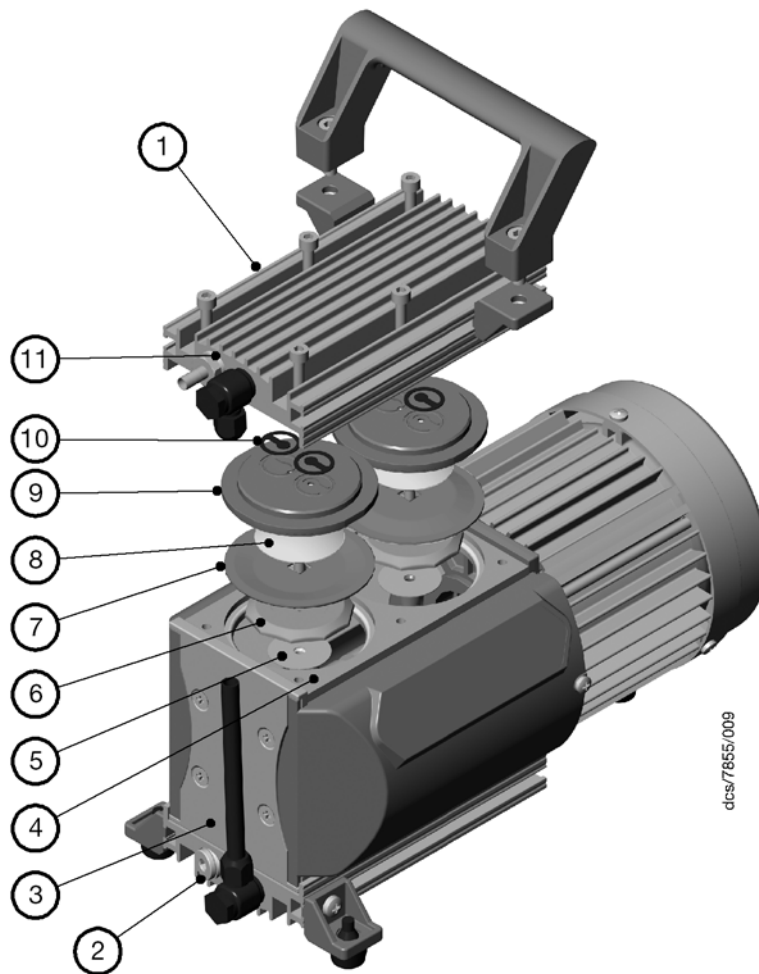

dcsl7855/009

- |                           |  |
|---------------------------|--|
| 1. Housing cover          | 7. Diaphragm                                     |
| 2. VS seal                | 8. Diaphragm clamping disc with connecting screw |
| 3. Bearing flange         | 9. Head cover                                    |
| 4. Housing                | 10. Valve  |
| 5. Rod                    | 11. VS seal                                      |
| 6. Diaphragm support disc |  |

Figure 9 - Tools required

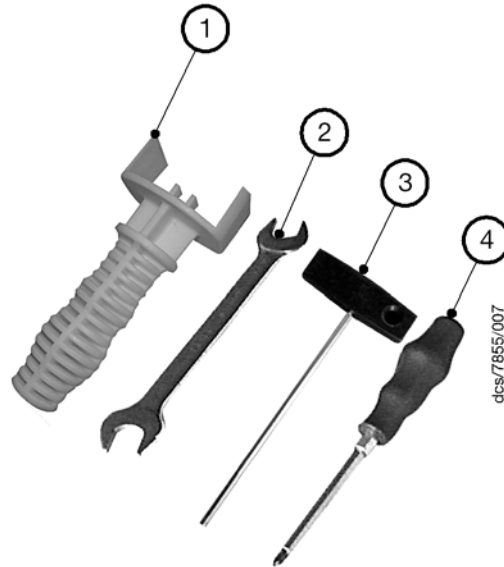

1. Diaphragm key SW 46 (included in service kit)
2. Open-ended wrench w/f 14
3. Hex key w/f 4/5
4. Phillips screw driver size 2

### 5.1.1 Cleaning and inspecting the pump heads

Use open-ended wrench to remove fitting at the pump head and remove together with connecting hose.

*Note:* Do not remove bearing flange (1).

Figure 10 - Remove the fitting at the pump head

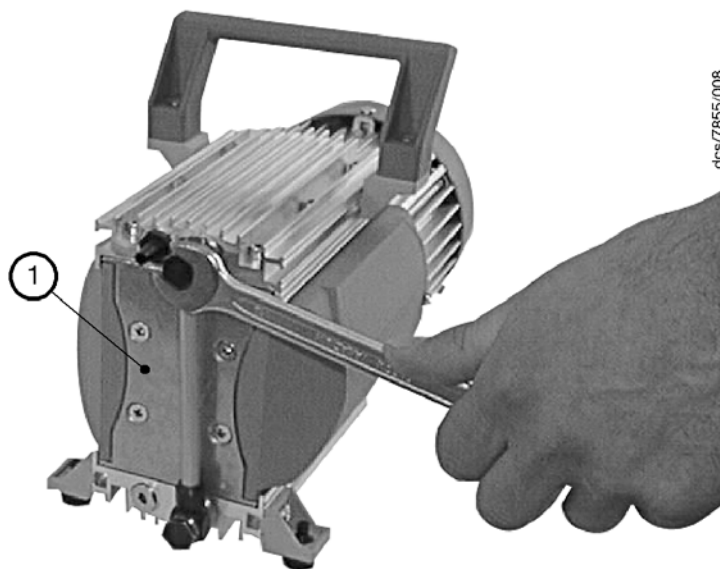

1. Bearing flange



Remove two screws at the handle and remove together with handle.

Figure 11 - Remove the handle

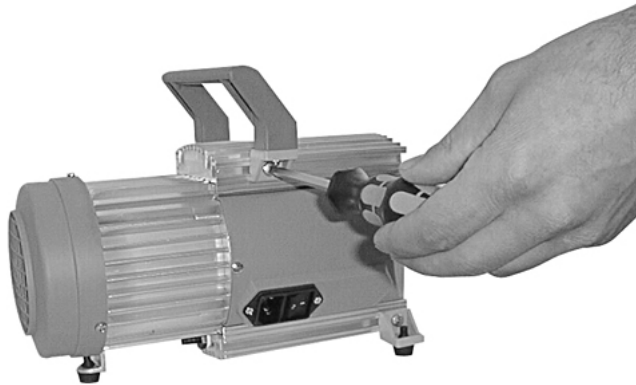

**WARNING**

Never remove parts by using a spiky or sharp-edged tool (e. g. screw driver), we recommend to use a rubber mallet or compressed air (to be blown carefully into port).

Use hex key to remove six socket head screws from pump head and remove upper housing (housing cover and head cover).

Figure 12 - Remove the housing cover and head cover

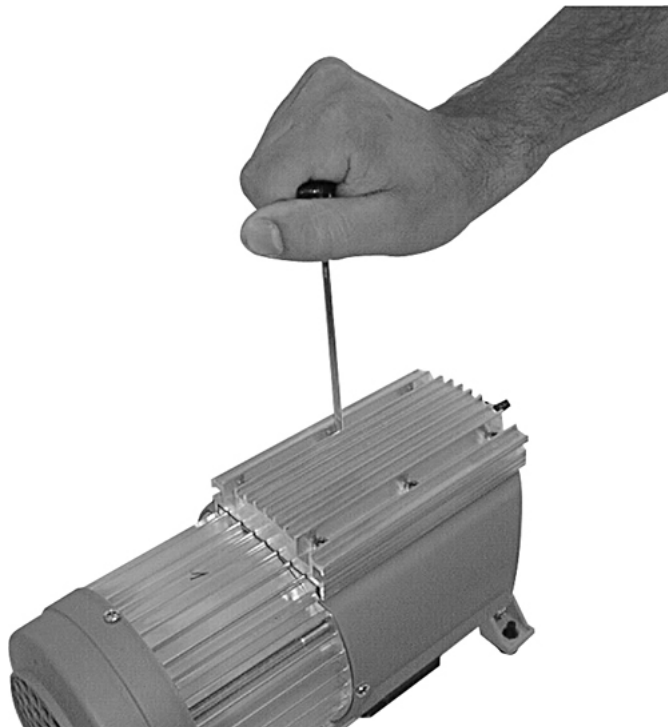

1. Remove head cover from housing cover and check valves. Note position of valves and remove.
2. Replace valves if necessary.
3. If necessary, use a suitable solvent to remove deposits.
4. Check diaphragm for damage and replace if necessary.

Figure 13 - Remove the head cover from the housing cover

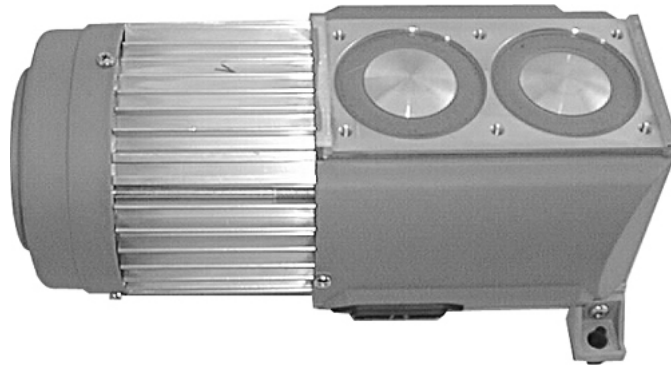

### 5.1.2 Replacing the diaphragm



#### **WARNING**

Never use a spiky or sharp-edged tool to lift the diaphragm.

1. Lift diaphragm carefully.
2. Apply pressure to the clamping disc beside the diaphragm to bring connecting rod into upper turning point position if necessary.
3. Use diaphragm key to grip under the diaphragm to the diaphragm support disc.
4. Apply pressure to the diaphragm clamping disc to bring the diaphragm into lower turning point position. Press diaphragm key against diaphragm clamping disc and unscrew diaphragm support disc with diaphragm.
5. If the old diaphragm is difficult to separate from the support disc, immerse the assembly in a suitable solvent in order to aid separation of the two parts.

Figure 14 - Lift the diaphragm

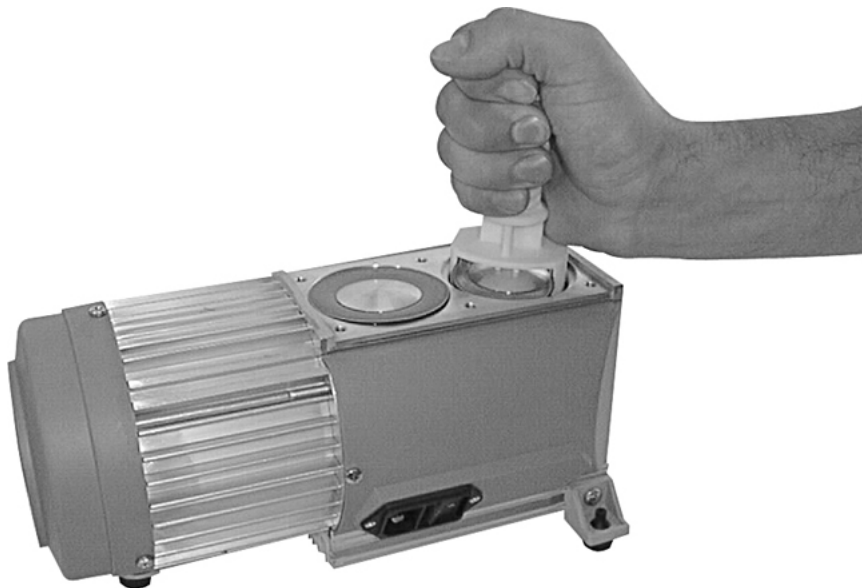

---

**CAUTION**

Check for washers under clamping disc. Do not mix the washers from the different heads. Make sure that the original number is reassembled at the individual pump head.

---

6. Position new diaphragm between diaphragm clamping disc with square head screw and diaphragm support disc.

*Note:* Position diaphragm with white PTFE side to diaphragm clamping disc (to pump chamber).

Figure 15 - Position a new diaphragm



7. Lift diaphragm at the side and position carefully together with diaphragm clamping disc and diaphragm support disc in the diaphragm key.

---

**CAUTION**

Avoid damage of the diaphragm: Do not crack diaphragm in a way that light lines at the diaphragm upper side occur.

---

8. Smaller number of washers: The pump will not attain final vacuum. More washers: Clamping disc will hit head cover; noise or even blockage of the pump.

Figure 16 - Diaphragm clamping disc

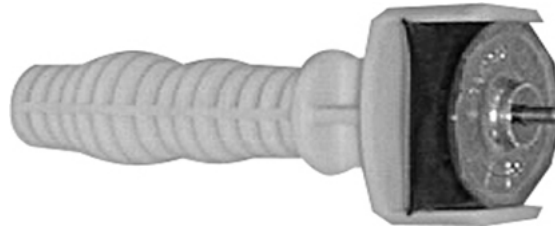

### 5.1.3 Assembling pump heads



#### **WARNING**

Do not turn or change housing covers!

1. Make sure that the square head screw of the diaphragm clamping disc is correctly seated in the guide hole of the diaphragm support disc.
2. Assemble diaphragm clamping disc, diaphragm and diaphragm support disc to connecting rod.
3. Position washers if available between diaphragm support disc and rod.

Figure 17 - Assemble the diaphragm assembly to the connecting rod



4. Bring diaphragm into a position in which diaphragm is in contact with housing and centred with respect to bore.

Figure 18 - Position the diaphragm

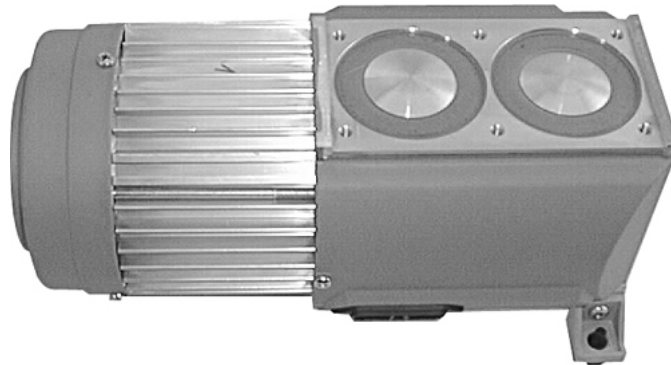

5. Assemble head cover and valves. Check for correct position (refer to [Figure 19](#) below).

Figure 19 - Assemble the head cover and valves

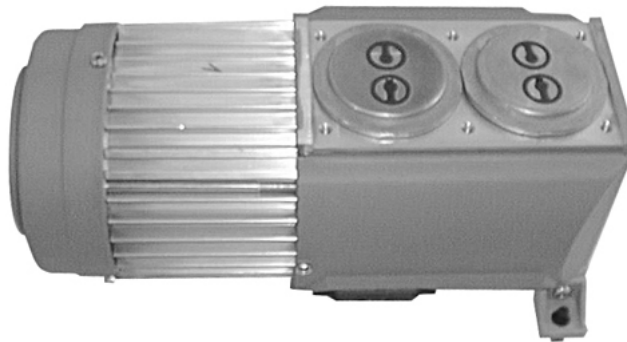

---

**CAUTION**

Obey position and orientation of the head covers and the valves definitely.

---

Figure 20 - Scheme pump head with head covers

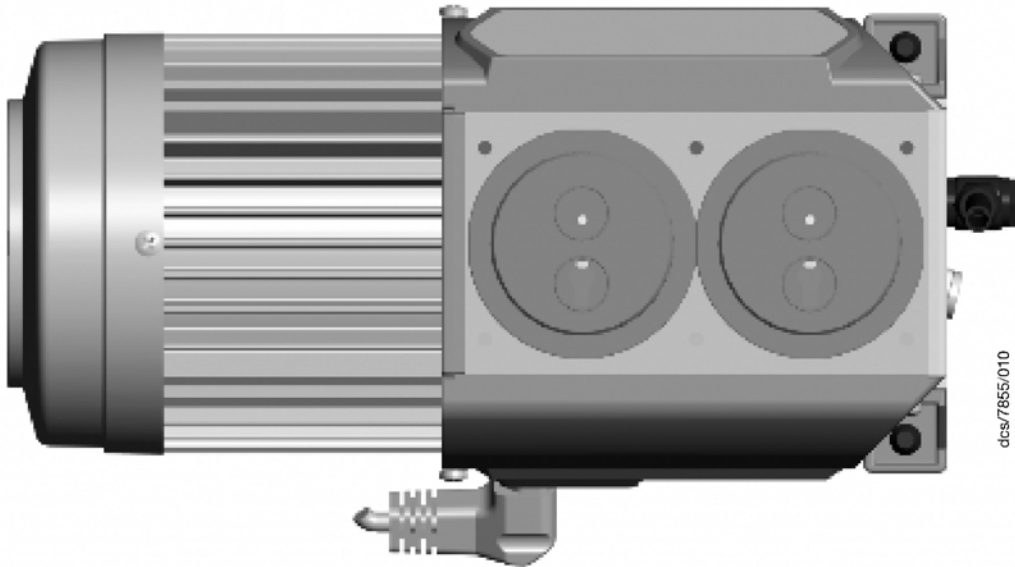
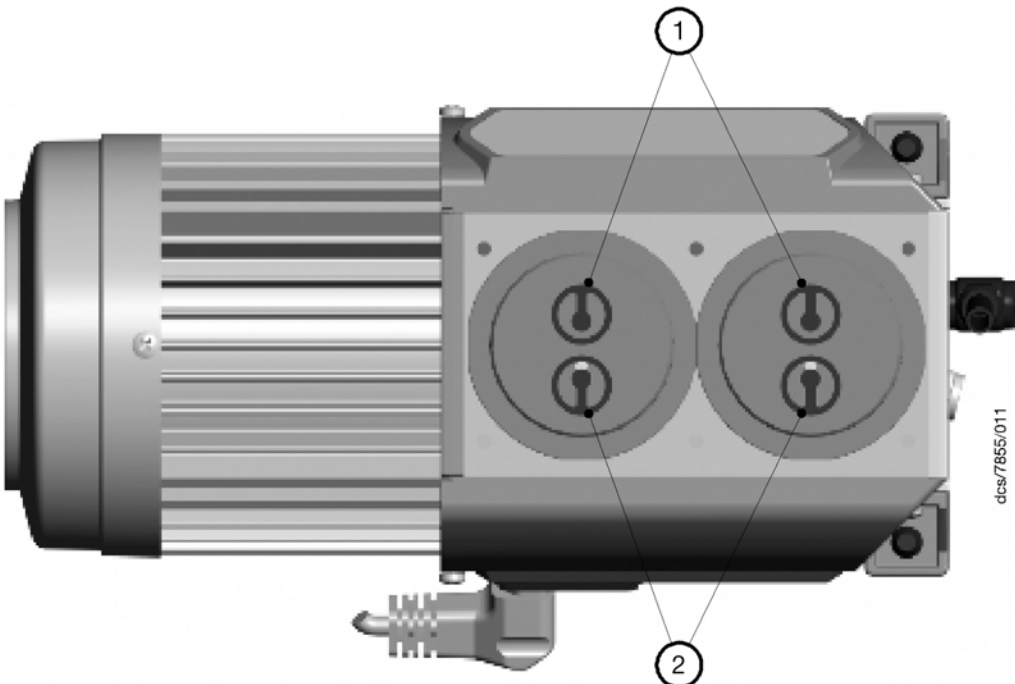

Figure 21 - Scheme pump head with head covers and valves



- 1. Valves at the outlet (round centred opening under valve)
- 2. Valves at the inlet (kidney-shaped opening beside valve)

- 6. Position housing cover.
- 7. Move housing cover slightly to make sure that the head covers are correctly positioned.
- 8. Screw in six socket head screws fixing housing cover crosswise first slightly, then tighten.

**Note:** Do not tighten until head cover is in contact with housing, max. torque 6 Nm.

Figure 22 - Position the housing cover

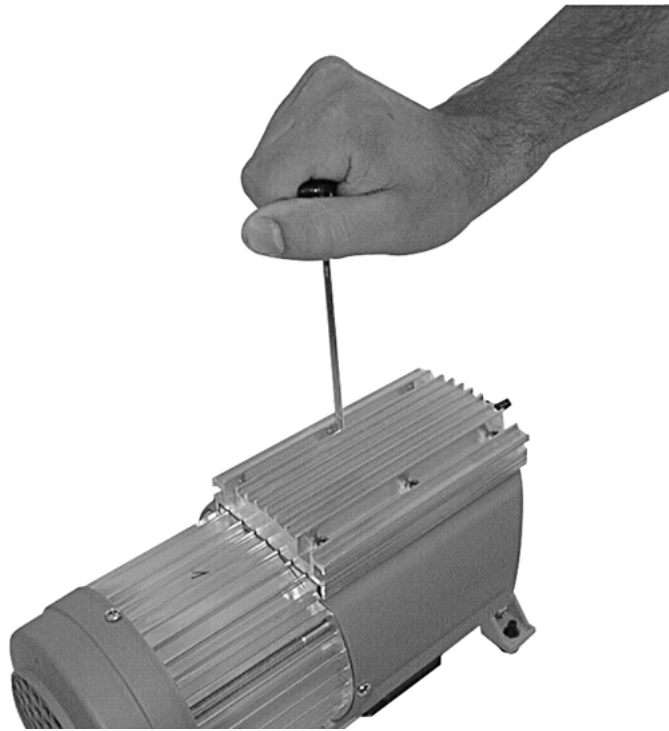

9. Assemble handle with screws and tighten.

*Note:* Check for correct position of the handle over the centre of gravity of the pump. The handle is in correct position if the end of the handle is positioned over the end of the housing cover.

Figure 23 - Assemble the handle

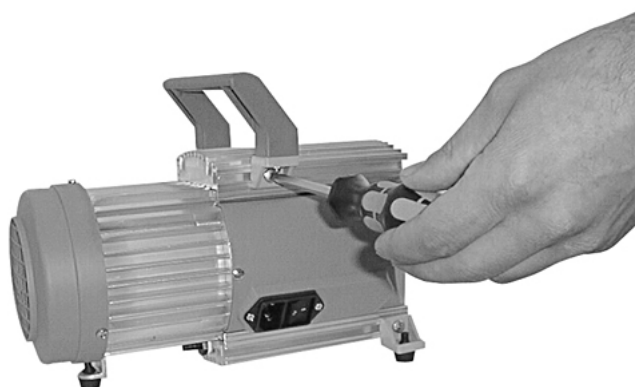

#### 5.1.4 Assembling fittings

1. Use open ended wrench to reconnect fittings with connection hose to pump heads.
2. Fix the ring nut when tightening the hollow bolt.

Figure 24 - Assemble the fitting at the pump head

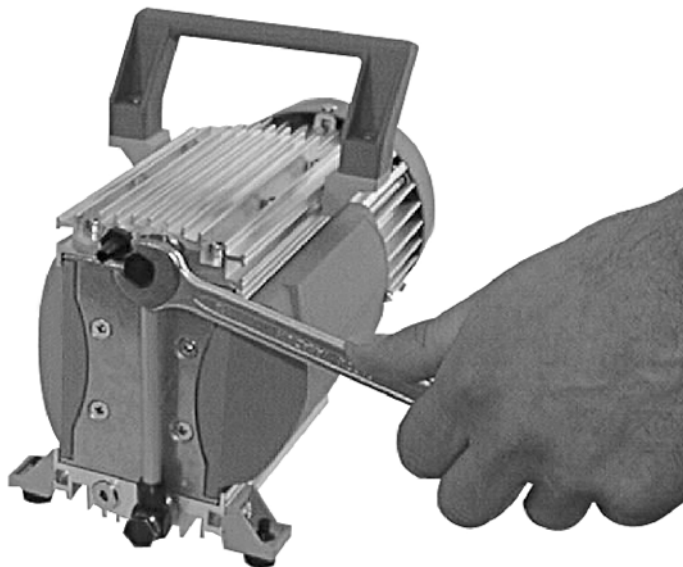

#### 5.1.5 If the pump does not achieve the ultimate pressure

In case the diaphragms and valves have been replaced, a run-in period of several hours is required before the pump achieves its ultimate vacuum.

If pump does not achieve the ultimate total pressure:

- Check hose connectors between pump heads and manifolds for leaks.
- If necessary recheck pump chamber.



Table 7 - Troubleshooting

Fault	Possible cause	Remedy
Pump fails to start or stops immediately.	<p>Supply voltage is missing or too low?</p> <p><b>Only 24 V DC version:</b> Control signal for motor speed is missing?</p> <p>Pressure in outlet pipeline too high?</p> <p><b>Only pumps with dual-voltage motor:</b> Motor overloaded?</p> <p>The motor fuse has blown</p>	<p>Check or connect supply voltage.</p> <p>Check control signal.</p> <p>Remove blockade in line, open valve.</p> <p>Manual reset is necessary. Switch off the pump or isolate the equipment from mains. Wait approx. five minutes before restarting the pump. Identify cause of failure and eliminate.</p> <p>Replace fuse (refer to <a href="#">Table 1</a>). Identify and eliminate cause of failure.</p>
Pump does not achieve ultimate total pressure or normal pumping speed.	<p>Centring ring not correctly positioned or leak in the pipeline or vacuum system?</p> <p>Long narrow line?</p> <p>Pump has been exposed to condensate?</p> <p>Deposits have been formed inside the pump?</p> <p>Valves or diaphragm damaged?</p> <p>Outgasing substances or vapour generated in the process?</p> <p><b>Only 24 V DC version:</b> Pump temperature too high (reduced motor speed)?</p>	<p>Check pump with a vacuum gauge directly at pump inlet port, check connections and line.</p> <p>Use line with larger diameter, length as short as possible.</p> <p>Run pump at atmospheric pressure for a few minutes.</p> <p>Clean and inspect pump heads.</p> <p>Replace valves and/or diaphragms.</p> <p>Check process parameters.</p> <p>Ensure sufficient cooling of the pump or reduce inlet pressure.</p>
Pump too noisy.	<p>Atmospheric or high pressure at inlet port?</p> <p>Diaphragm clamping disc loose?</p> <p>None of above mentioned causes?</p>	<p>Connect hose to pump outlet.</p> <p>Perform maintenance.</p> <p>Contact your supplier.</p>
Pump seized.		Contact your supplier.

This page has been intentionally left blank.

## 6 Storage and disposal

### 6.1 Storage

Use the following procedure to store the pump:

Close the vacuum system isolation valve to prevent suckback into the vacuum system. Switch off the pump using the on/off switch on the motor. Disconnect the pump from the electrical supply. Purge your vacuum system and the pump with dry nitrogen and disconnect the pump from your vacuum system. Place and secure protective covers over the inlet and outlet ports.

Store the pump in cool, dry conditions until required for use.

### 6.2 Disposal

Dispose of the pump and any components from it safely in accordance with all local and national safety and environmental requirements. Particular care must be taken with components which have been contaminated with dangerous process substances.

Do not incinerate fluoroelastomer seals and O-rings.

This page has been intentionally left blank.

## 7 Spares and accessories

### 7.1 List of spare parts

Table 8 - Spare parts

Item number	Description
A746-01-700	Inlet flange spare XDD1
A746-01-701	VS seal spare XDD1
A746-01-702	Exhaust silencer spare XDD1
A746-01-800	Diaphragm service kit XDD1
A746-01-703	Fan cover white, XDD 1, 115/230 V, 50/60 Hz
A746-01-704	Motor cover white, XDD 1, 24 V DC
A746-01-705	Anti-vibration mount

This page has been intentionally left blank.